

THIS COPY IS PROVIDED ON A RESTRICTED BASIS AND IS NOT TO BE USED IN ANY WAY DETRIMENTAL TO THE INTERESTS OF PANDUIT CORP.

NOTES:

1. DIMENSIONS IN [] ARE IN MILLIMETERS.

PANDUIT PART NO.	MATERIAL	FACE COLOR	PKG. QTY.	THICKNESS	PRODUCT TYPE
C120X150A0T-22	GMH3	BLACK	500	.030 +/- .010	POLYESTER/ FOAM COMPONENT LABEL
C120X150A8T-22		YELLOW			
C120X150APT-22	GMH3-W	WHITE			
C120X150AST-22	GMH3	GREEN			
C120X150AWT-22		RED			

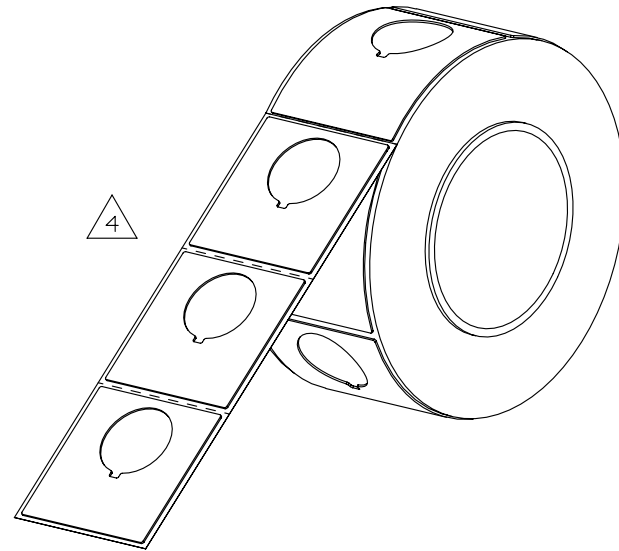
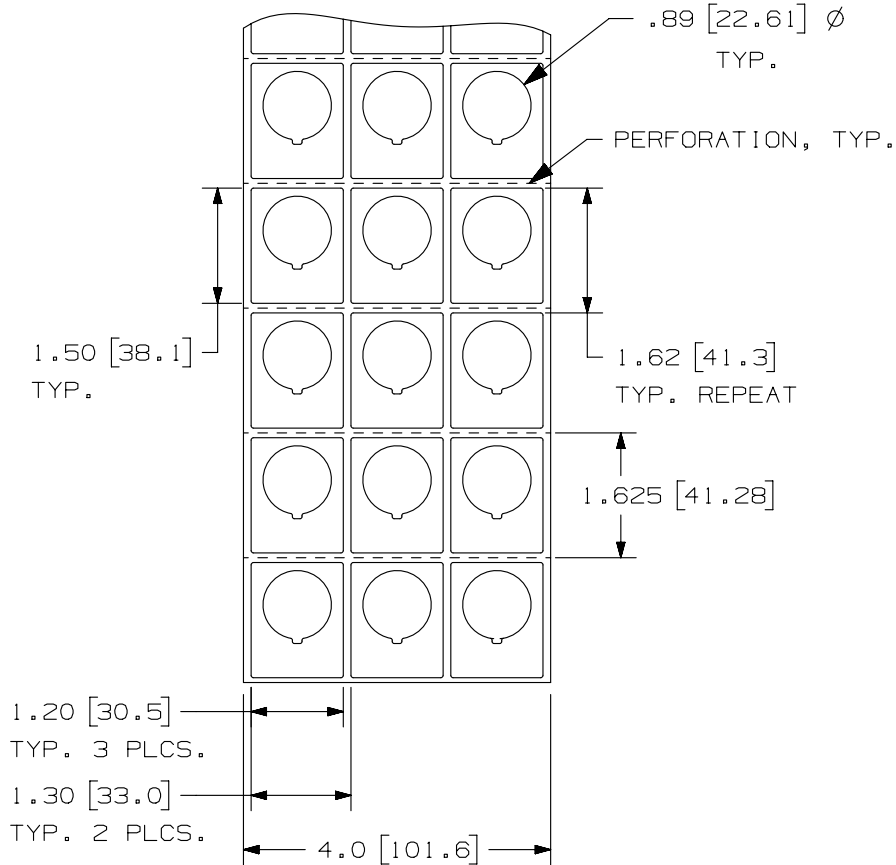

REV	DATE	BY	CHK	APR	DESCRIPTION	ECN
4	1/7/13	RVU	DAPE	SEWH	ADD material column and ISO view. UPDATE PART NUMBERS SEQUENCE LIST.	GAECN00507
3	5/3/10	RVU	DAPE		TOL. SHOULD BE .12, .062, NOT .1, .050.	6036
2	1/30/09	RVU	DAPE		REMOVE "REPEAT" FROM THE LABEL SIZE. ADD DIM. PERF. VERTICAL. REMOVE C120X150AMT-22.	5592
1	12/18/08	RVU	DAPE		VOID	
0	9/5/08	RVU	DAPE		DRAWING RELEASE.	5537

TITLE						
RAISED PANEL PUSH BUTTON LABELS C120X150APT-22 CUSTOMER DRAWING						
ITEM REVISION NAME				100491BL/05		
DATASET FILE NAME				100491BL-DC-C10725/05F		
UNLESS OTHERWISE SPECIFIED, DIMENSIONAL TOLERANCES ARE: IN [mm]				PANDUIT TM MATERIAL: SEE TABLE		
.x ± .12 [3.05] .xxx ± .025 [.635] .xx ± .062 [1.57] ANGLES ±						
DRAWN BY				DATE	CHK	SCALE
RVU				9/5/08	MSAD	NTS
DRAWING NUMBER:				C10725		
SHT 1 OF 1				A		

D10100DA/12